



Specialized in Oil & Gas
Equipment and Technology

6329 – 76 Avenue,
Edmonton, AB
T6B 0A7 Canada
Phone: (780) 485-0915
Fax: (780) 485-0914

Mitey TITAN LOAD MANAGER/STABILIZER SYSTEM

HIGHLIGHTED FEATURES:

- ▲ Mitey Titan Load Manager/Stabilizer can be used with any Rig-Assisted or Stanalone Snubbing Units
- ▲ Option: Self Moving Load Manager with tracks and hydraulic controls to move snubbing unit without using heavy picker or crane
- ▲ Platform size customized as per application
- ▲ Option: Manual or Hydraulic Controls
- ▲ Load Capacity: Custom Designed upto 150,000 lbs
- ▲ Option: 10,000 Psi Load Manager Complete with BOP's available with changeover 10K to 5K Spool
- ▲ Option: Removable center spool
- ▲ Option: Integrated Hanger Flange in center spool
- ▲ Option: Offset work platform without self-moving
- ▲ Option: One platform with fold-down catwalks
- ▲ Quick connect Inlet/Outlet panel marked clearly for each connection
- ▲ OH&S approved removable & extendable stairs and handrails to either work platform
- ▲ Highest Quality product with all components engineered with 2.5 safety factors
- ▲ Customization as per client requirements

MTech Industries also manufactures and sells complete line of snubbing units, hydraulic catwalks, Catwalk Style Pipe Racks, BOP's, Pipeline Roller Units, Moving Pipe Restrainer, and other pipe handling and safety products

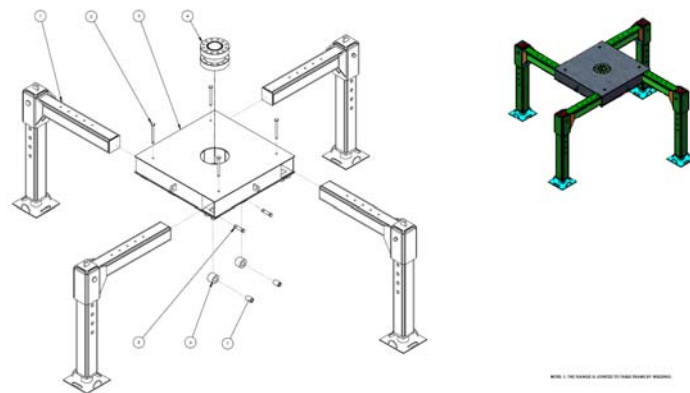
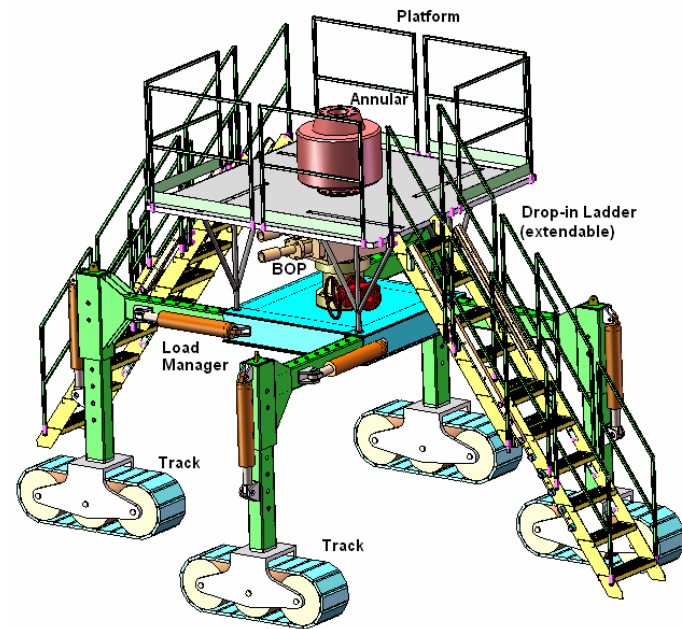

For Product Inquires, Please Contact:
Telephone: +1 (780) 485 - 0915
Email: info@mtechind.com
Website: www.mtechind.com

